

---

**INSTALLATION AND OPERATOR'S MANUAL**

***EMERALD SERIES***

***EM-85 THRU EM-200***

**OIL FIRED PACKAGED BOILER BURNER UNIT**

**COLUMBIA®**

**COLUMBIA BOILER CO. OF POTTSTOWN**

POTTSTOWN, PENNSYLVANIA 19464

# EMERALD SERIES BOILER

## BASIC BOILER COMPONENTS

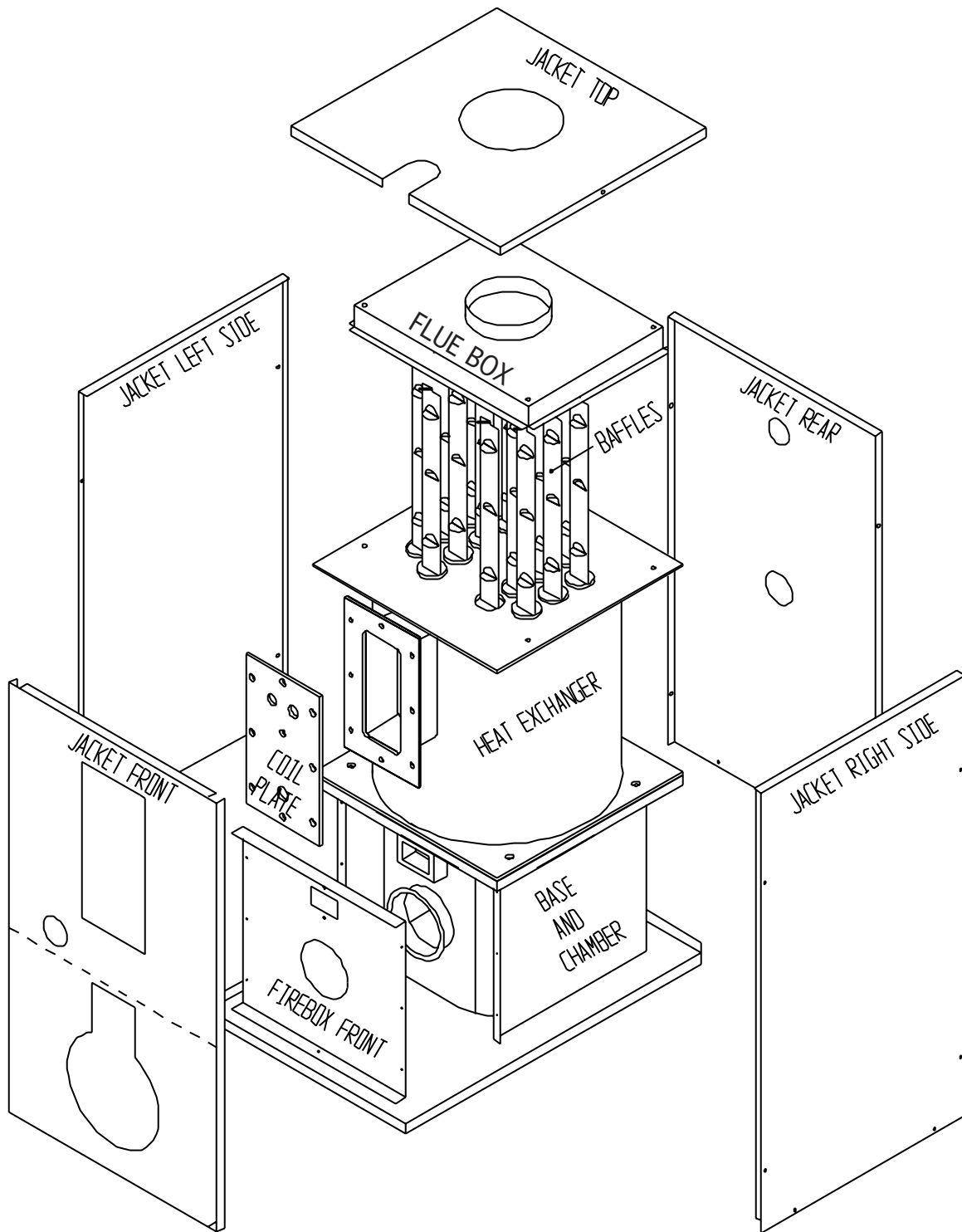

# Homeowner / Installer Policy

We at Columbia Boiler Company would like to “Thank You” for choosing our top of the line Emerald Series Boiler. At Columbia Boiler we take pride in the serviceability and the quality construction of our products. We have built trusting relationships that date back through our company’s history to 1936. We believe that personal service is the best service and our customers agree.

We would like to offer you a few helpful service points to insure your family years of trouble free comfort. In order to maintain peak performance of your boiler, it is recommended that your boiler be maintained annually. Servicing of your appliance must be performed by a qualified oil heating technician. A properly trained oil technician will be prepared to set your boiler/burner combination with the proper tools necessary to achieve your maximum comfort and efficiency.

As a family owned business, we are happy to have you as one of our many satisfied homeowners who have been choosing Columbia boilers for over 70 years. We look forward to a long and continued relationship.

Rosemarie Bartchak  
Sales and Marketing Manager  
Columbia Boiler Residential Sales

## TABLE OF CONTENTS

	Page
Emerald Series Boiler Ratings and Dimensions .....	1
Installation and Operating Information .....	2
Piping Diagram .....	6
Trouble Shooting Guide .....	7
Wiring Diagrams .....	12-13
Burner Service Set-Up Records .....	14-15
Emerald Series Boiler/Burner Unit Specifications .....	16

# EMERALD SERIES

# PACKAGED, HYDRONIC HEATING BOILERS

## IBR/DOE RATINGS AND DATA

Boiler Model No.	EM-85	EM-100	EM-3100	EM-110	EM-125	EM-3125	EM-135	EM-150	EM-165	EM-175	EM-200
Firing Rate -- #2 Fuel	.85	1.00	1.00	1.10	1.25	1.25	1.35	1.50	1.65	1.75	2.00
Input -- MBTU/Hr.	119	140	140	154	175	175	189	210	231	245	280
DOE Heating Capacity MBTU/Hr.	101	118	119	130	148	146	159	176	183	205	234
Net IBR Rating MBTU/Hr.	88	103	103	113	129	127	138	153	168	178	203
GPM Tankless Coil	3	5	5	5	5	5	5	5	5	5	5

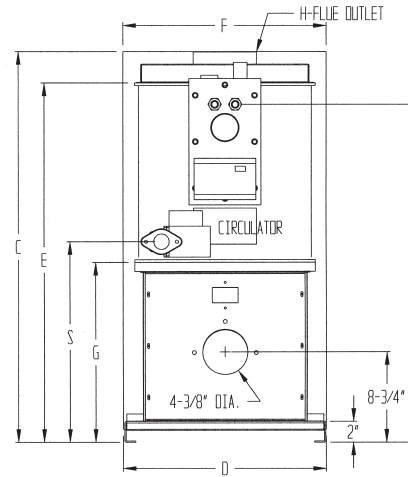
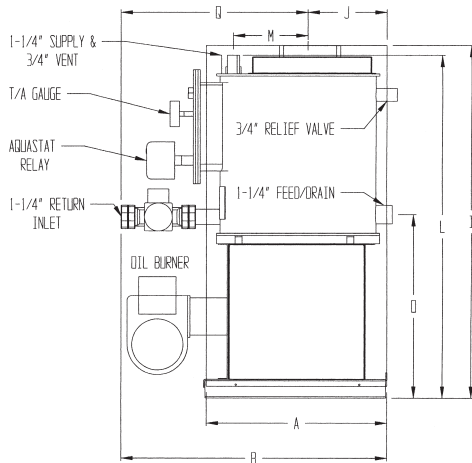

DIMENSIONS (INCHES)		EM-85	EM-100	EM-3100	EM-110	EM-125	EM-3125	EM-135	EM-150	EM-165	EM-175	EM-200
Casing	A Length	20"	20"	21"	20"	20"	21"	21"	21"	21"	21"	21"
	C Height	37-1/4"	37-1/4"	46"	37-1/4"	37-1/4"	46"	46"	46"	46"	46"	46"
	D Width	19-1/2"	19-1/2"	21"	19-1/2"	19-1/2"	21"	21"	21"	21"	21"	21"
Boiler	E Height	34-3/8"	34-3/8"	43-3/8"	34-3/8"	34-3/8"	43-3/8"	43-3/8"	43-3/8"	43-3/8"	43-3/8"	43-3/8"
	F Diameter	16-3/4"	16-3/4"	18-3/4"	16-3/4"	16-3/4"	18-3/4"	18-3/4"	18-3/4"	18-3/4"	18-3/4"	18-3/4"
	G Base Hgt.	17"	17"	20-1/2"	17"	17"	20-1/2"	20-1/2"	20-1/2"	20-1/2"	20-1/2"	20-1/2"
Flue Outlet	H Size	6"	6"	6"	6"	6"	6"	8"	8"	8"	8"	8"
	I Height	37-1/2"	37-1/2"	47"	37-1/2"	37-1/2"	47"	47"	47"	47"	47"	47"
Supply Outlet	J C.L. to Rear	9"	9"	10-1/2"	9"	9"	10-1/2"	10-1/2"	10-1/2"	10-1/2"	10-1/2"	10-1/2"
	L Height	35-1/4"	35-1/4"	45"	35-1/4"	35-1/4"	45"	45"	45"	45"	45"	45"
Feed/Drain	M C.L. to Outlet	9"	9"	8-3/8"	9"	9"	8-3/8"	8-3/8"	8-3/8"	8-3/8"	8-3/8"	8-3/8"
	O Height	19-1/4"	19-1/4"	22-3/4"	19-1/4"	19-1/4"	22-3/4"	22-3/4"	22-3/4"	22-3/4"	22-3/4"	22-3/4"
Return Inlet	Q C.L. to Inlet	20"	20"	20"	20"	20"	20"	20"	20"	20"	20"	20"
	S Height	19"	19"	22-1/2"	19"	19"	22-1/2"	22-1/2"	22-1/2"	22-1/2"	22-1/2"	22-1/2"
Coil Conn.	Nominal Size	1/2"	1/2"	1/2"	1/2"	1/2"	1/2"	1/2"	1/2"	1/2"	1/2"	1/2"
	U Height	32-1/4"	32-1/4"	42"	32-1/4"	32-1/4"	42"	42"	42"	42"	42"	42"

**COLUMBIA BOILER CO.**  
OF POTTSTOWN  
BOX G, POTTSTOWN, PA 19464



# COLUMBIA

## COLUMBIA BOILER CO. OF POTTSTOWN

Box G, Pottstown, Pennsylvania 19464

A Message to: Installer, Serviceman, Homeowner:

Over sixty years of engineering and product development have gone into your new Columbia oil fired boiler. It's quality and design are unsurpassed. Properly installed and maintained, it will provide many years of efficient and dependable operation. Please read this Instruction Manual carefully. The information contained within is designed to help you maintain peak performance from your boiler/burner unit.

### A. Installation Instructions

#### **CAUTION:**

1. *Installer must be a trained, experienced serviceman.*
2. *Inspect the boiler, jacket and all components to be sure damage has not occurred in shipment. If damage is evident you must file a claim with the freight carrier immediately.*
3. *Disconnect power supply before connecting wiring.*
4. *Refer to local installation codes for oil burning equipment, for recommended installation practice.*
5. *A complete heat loss calculation is necessary to choose the proper size unit to install. The boiler should be sized to within 25% of the actual heat loss of the structure.*
6. *Conduct thorough checkout when installation is complete.*

1) Place the boiler on a level non-combustible floor, preferably raised and as close to the chimney as possible. The following minimum clearances must be adhered to during installation and maintained thereafter to properly clean, inspect and service your boiler: sides and back - 6"; front - 24" and vent connector - 18". Reduced clearance installations must follow NFPA-31 guidelines.

2) For location of piping refer to the installation drawing in Figure 1. The burner, aquastat and circulator are wired at the factory. For power and thermostat (not supplied) wiring connections see the control manuals provided along with this manual. For piping and wiring of other system components see the manufacturers installation manuals.

3) The tankless water heater may be piped as shown in Figure 1. A mixing valve, not supplied, must be used to reduce the water temperature at kitchen or bathroom taps. High temperature water for a dishwasher may be obtained by piping as shown in

Figure 1. The nuts that secure the tankless coil flange should be tightened before the boiler is filled with water, after initial firing and once a year during the annual maintenance. DETERIORATION DUE TO COIL GASKET LEAKS WILL VOID THE WARRANTY.

3a) This style of boiler is equipped with a built in "Air Scoop System." This feature allows quiet air free operation of your hot water system by assuring the removal of air pockets without the installation of Air Scoops to trap noisy air.

The 1-1/4" supply line or Riser tapping in the top of the boiler extends approximately 1" below the top or waterline of the boiler, thus allowing only air free water to enter the supply to the heating system. The air trapped in the top of the boiler is then purged through a 3/4" vent tapping to be released with an (1) automatic float vent (2) a manual vent or (3) piped into a conventional type expansion tank.

Relief valve discharges and drain valve piping should be piped to a safe place of discharge. All plugs and water connections should be checked for leaks upon installation and annually.

- 4) Be certain the chimney is clean and free of obstructions. Connect boiler flue outlet to chimney using galvanized smoke pipe. The flue pipe should be pitched upward at least 1/4" per foot of run. Refer to Page 1 in this manual for proper size flue pipe for your model boiler. Use only elbows and straight sections. Tees may be used in a straight section in conjunction with a barometric draft regulator; however, they must not be used for a 90° turn. Each joint should be securely fastened with sheet metal screws. The flue pipe must not be inserted beyond the inside wall of the chimney. Install barometric draft regulator in the horizontal or vertical section of the flue pipe.
- 5) The boiler room must be well ventilated to allow sufficient make-up air to support combustion. Lack of adequate combustion air may result in erratic operation of the burner, noisy combustion or fuel odors. Remember your need for outside air will be greatly increased if you have a vented dryer in the basement or other venting fans in the home. Boilers located in confined spaces shall be provided with two permanent openings, one near the top and one near the bottom of the enclosure. Each opening shall have a free area of not less than one square inch per 1000 BTU per hour input rating of the boiler, freely communicating with interior areas having adequate infiltration from the outside.
- 6) Fill boiler and system with water. Be sure entire system has been purged of air and the desired pressure is obtained.
- 7) Connect burner to oil supply. Refer to fuel unit manufacturer literature for piping, connections, lift and tank installation. If such information is unavailable use the following guidelines.

## FUEL UNITS/FUEL LINES

Fuel supply "level with" or "above" burner: A single stage fuel unit connected to the fuel supply with a single supply line is the most common

type of installation for these conditions. Manual venting of the fuel unit is usually required on initial start-up. Failure to vent air could result in an air lock/oil starvation condition. (One pipe)

Fuel supply below the level of burner: Use a single stage fuel unit in lift conditions of up to 10 ft., and a two stage fuel unit when the lift exceeds 10 ft. Both conditions require the use of a return line which helps to purge the fuel unit of air returning it to the fuel tank. The "by-pass" plug must be inserted into the fuel unit when installing a return line. (Two pipe)

Fuel line installation: Continuous lengths of heavy wall copper tubing are recommended and should be installed under the floor when possible. Always use flare fittings. Always install fittings in accessible locations. Never use teflon tape on any fuel fitting. Use of teflon will void any pump warranty. Fuel lines should not run against the appliance or the ceiling joists.

Fuel line valve and filter: Install two high quality shutoff valve(s) in accessible locations on the oil supply line. Locate one close to the tank and the other close to the burner ahead of the filter. Some filters come with built-in shutoff valves. Install a generous capacity filter inside the building between the fuel tank shutoff valve and the burner locating both the filter and the valve close to the burner for ease of servicing.

**Always use flare fittings.**  
**Never use compression fittings.**

### **IMPORTANT**

All oil feed lines to burners must be air tight. Use only flare fittings when assembling oil lines since the slightest air leak, caused by loose fittings, bad gaskets or any other reason, can cause a foaming oil stream which will cause any of the following conditions:

- a) Intermittent firing, causing safety shutdown
- b) Poor starts
- c) Smokey starts
- d) Continual sooting of boiler and burner parts including the cad cell
- e) Reduced firing rate, inefficient operation and erratic fire pattern

- f) A dangerous combustion condition, allowing the firebox to fill with a lean mixture (too much air in the oil stream) which could cause a delay in ignition of the fuel mixture until the danger point has been reached.

Suction vacuum must be held to acceptable limits. The vacuum test is worth the time required to make it. This problem becomes proportionately larger with underground tanks. If the following procedures are followed, burner related problems will be minimized:

- a) Connect vacuum gauge to oil pump. Suction vacuum must not exceed 10 inches of mercury for single stage pumps and 15 inches for two stage pumps. It is preferable to stay below these limitations.
- b) When the suction line is tight and properly installed the pump will hold its vacuum for a minimum of 60 minutes after shutdown.
- c) Installation of a check valve in the suction line of a two pipe system is advisable under all circumstances. Be sure the check valve fittings are airtight.
- d) Connect the electric supply to the boiler as indicated on the wiring diagrams. The wiring must be installed in accordance with the National Electrical Code and any other state and local codes.

### C. Operational Sequence

- 1) Boilers with Tankless Coil - This boiler is equipped with a combination aquastat control which has high and low limits to be set at 180° and 160° respectively by the installer. When room temperature falls below thermostat setting, thermostat calls for heat starting the burner and circulating pump. The burner and pump continue to operate until room heating requirements are satisfied (thermostat setting is reached), or until boiler water temperature reaches the high limit control temperature setting. If the high limit control temperature setting is reached, the burner shuts off and the circulating pump continues to operate until the room heating requirements are satisfied. If the thermostat continues to call for heat after the boiler water temperature has dropped below the temperature setting of the high limit control, the oil burner will start again, while the circulating pump will continue to run. The boiler water

temperature is normally maintained at 160°F around the tankless coil by the operating control so that an abundance of hot water is available. If the boiler water temperature should fall below the operating control setting (160°F) the oil burner will be started again by that control (and the circulating pump will be prevented from operating) until the operating control setting is satisfied. See control manufacturers literature included in the data package for detailed wiring, operating and safety instructions.

- 2) Boilers Less Tankless Coil - This boiler is equipped with a high limit aquastat control which should be set at 180° by the installer. The oil burner is operated in an identical sequence as 1), except that the boiler water temperature need not be maintained at a 160°F low limit setting since there is no domestic hot water load to protect. See control manufacturers literature included in the data package for detailed wiring, operating and safety instructions.
- 3) A cadmium sulfide flame scanner (cad cell) and relay are provided with the oil burner. The cad cell will stop the oil burner within a predetermined number of seconds if the fuel fails to ignite or if the flame goes out during operation. The oil burner will remain off until the red reset button on the relay has been pushed. **RESET MUST NEVER BE PRESSED MORE THAN ONCE DURING A SINGLE FLAME FAILURE.**

### D. Start-Up and Check-Out Procedure

#### **CAUTION**

*Only a trained, experienced serviceman should attempt the checkout procedure outlined below. Read the burner manufacturers instructions for start-up for special instructions and special features of the burner and control.*

- 1) Combustion test equipment required for proper burner adjustment:
  - a) CO<sub>2</sub> Analyzer
  - b) Draft Gauge
  - c) Oil Pressure Gauge 0-200 PSI
  - d) Stack Thermometer
  - e) Smoke Test Gun
  - f) Vacuum Gauge 0-30 in. of Hg

- 2) In order to take flue gas samples for combustion testing a 1/4" hole must be drilled in the flue pipe between the boiler and the barometric draft regulator.
- 3) Open all shut-off valves in the oil supply line to the burner.
- 4) Set thermostats substantially above room temperature.
- 5) Check electrode settings and readjust air setting if required. Electrode settings are shown in the burner manual provided along with this manual. Burner settings are listed on the Service Man's Label attached to the boiler and on the Burner Unit specifications provided along with this manual.
- 6) Install pressure gauge in the 1/8" gauge port of the oil pump.
- 7) Turn on switch to start burner. If burner does not start immediately, you may need to reset the burner control. See the burner manufacturers instructions for control and reset features.
- 8) On one pipe systems bleed the oil pump as soon as burner motor starts. To bleed, attach a length of 1/4" O.D. clear plastic tubing to the end of the bleed plug and then loosen plug while holding an empty container under the tubing to catch all of the expelled oil. Bleed for at least 15 seconds after the oil stream is free of all air. If air is still evident in the bleed line you must check the oil lines, all fittings, filters and any other connections for tightness. Kinks in the oil lines will create undue high vacuum therefore they must be eliminated. When you are sure all air has been eliminated then close the bleed valve. Ignition should be instantaneous following the closing of this valve. If it is not, proceed to the trouble shooting guide to determine why the oil did not ignite.
- 9) Be sure the oil pump discharge pressure is adjusted to 140 PSI. If it is not refer to the oil pump manufacturer's instruction sheet for pressure adjustment procedure.
- 10) FINAL ADJUSTMENTS OF THE BURNER MUST BE MADE USING PROPER COMBUSTION TEST EQUIPMENT. The air supply should be adjusted by loosening the lock screw and moving the bulk air band or shut-

ter so that the CO<sub>2</sub> measured in the stack ahead of the draft control should be a minimum of 10% and a maximum of 12%. At the same time the draft should be adjusted to -.01"-.02" W.C. over the fire. Install a second barometric draft control if necessary to reduce excessive draft. The smoke should also be checked with a smoke gun and found to be zero.

- 11) Check operation of the cad cell relay by removing one cad cell wire from external terminal during the flame cycle. The relay should cut the burner off in approximately 15 to 45 seconds, depending on the control provided. See the burner manufacturers manual provided in the data pack.

## E. Servicing the Boiler/Burner Unit

- 1) Burner Components: If replacement of burner parts is necessary, always use parts recommended by the manufacturer. Specify part number and description when ordering.
- 2) Electrode settings are important for reliable ignition of the oil. Check to be sure the settings are in accordance with the instructions provided in the burner manual.
- 3) Nozzles: The nozzle specifications listed in the manual are the result of years of exhaustive engineering testing. ANY NOZZLE REPLACEMENT SHOULD BE OF THE EXACT TYPE AS LISTED IN THE SPECIFICATIONS. Use extreme care in handling nozzles to avoid scratches or dirt that could cause leaks or affect the oil spray pattern.
- 4) Fan and blower housing should be kept clean of dirt and lint. If heating unit is located near an unvented dryer, special care must be taken so that lint does not clog the burner air inlets.
- 5) Replace the oil filter cartridge annually.
- 6) Cleaning the Boiler: Cleaning should be done only by a trained, experienced serviceman. Turn power off to the boiler. To clean the boiler, remove the flue pipe, jacket top and flue collector. Remove the baffles then clean the tubes with a soft 2" flue brush. Reinstall parts, readjust and clean the burner if required."

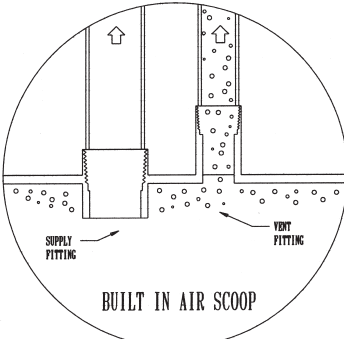
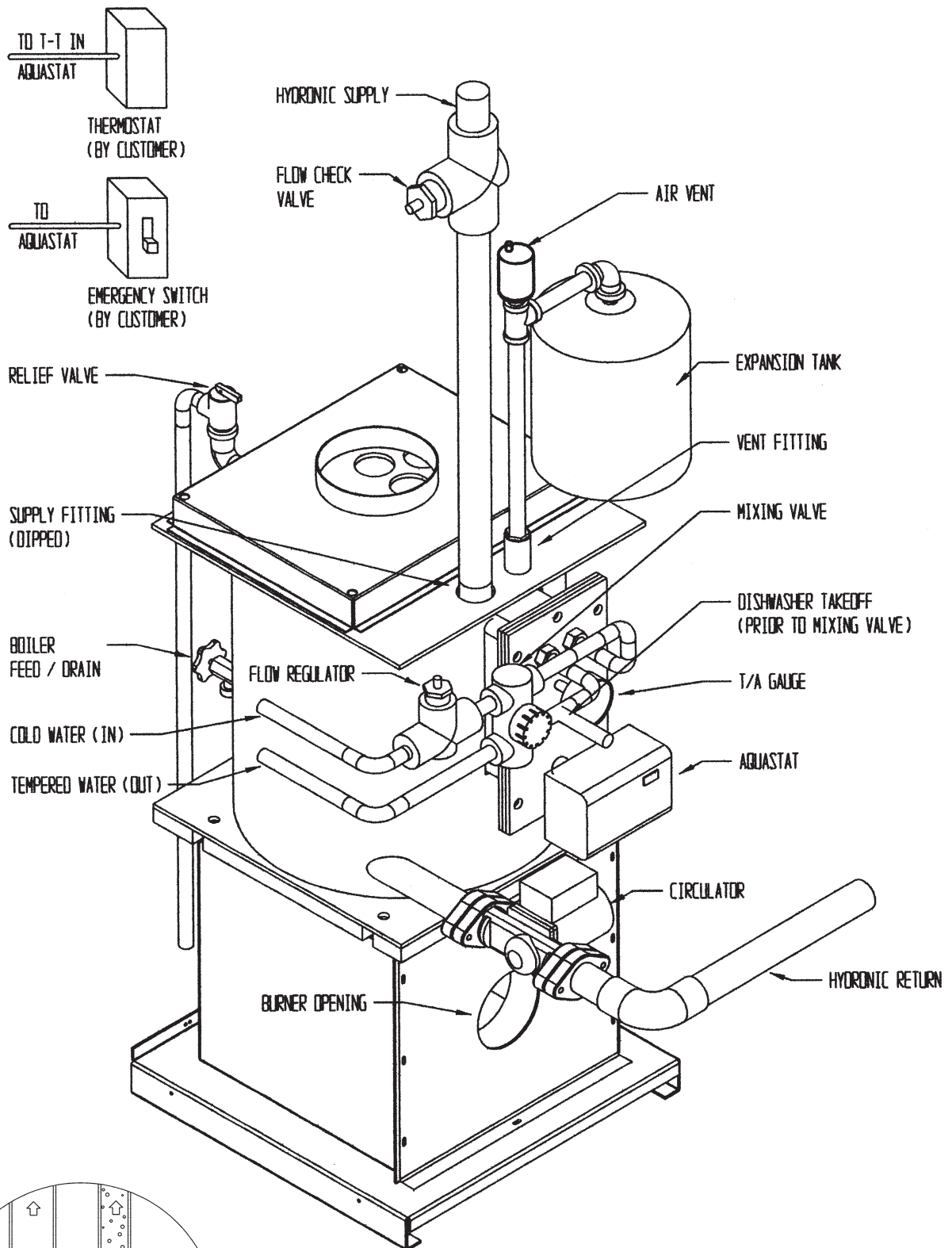

FIGURE 1

# Troubleshooting Guide

## TROUBLE: BURNER DOES NOT START

SOURCE	PROCEDURE	CAUSES	REMEDY
<i>Power</i>	Check boiler disconnect and main disconnect switch	Switch open.	Close switch.
		Tripped breaker or blown fuse	Reset breaker or replace fuse
<i>Thermostat</i>	Check thermostat settings	Thermostat set too low.	Turn up thermostat
		Thermostat on "off" or "cool"	Switch to heat
	Jump TT terminals on aquastat control. If burner starts, fault is in the thermostat circuit	Thermostat not level	Level thermostat
		Open thermostat wires	Repair or replace wires
		Loose thermostat connectors	Tighten connection
		Faulty thermostat	Replace thermostat
<i>Circuit Resets</i>	Check burner motor overload switch, if equipped	Burner motor tripped on overload	Press reset button
	Check primary control safety switch.	Primary tripped on safety	Press reset button
<i>Aquastat Control</i>	Check limit settings versus boiler water temperature	Burner off on limit	Adjust limit settings
	Check for voltage at L1 and L2	Open safety switch, tripped breaker or blown fuse	Close switch, reset breaker or replace fuse
	Jump TT terminals on aquastat then check for voltage at terminals B1 and B2	No voltage indicates defective control	Replace control
<i>Primary Control</i>	Check for voltage between the black and white leads. No voltage indicates no power to the control. Make sure the the jumper on TT terminals is installed	Aquastat limit control switch open	Check limit setting.
		Open circuit between limit control and primary control if voltage is present at B1 and B2 of aquastat	Repair circuit.
<i>Burner</i>	Check for voltage burner motor. Voltage indicates power to motor and a fault in the burner.	Pump seized.	Turn off power to burner. Rotate blower by hand, check for excessive drag. Replace fuel unit or blower wheel.
		Blower wheel binding	
		Burner motor defective	Replace burner motor

## TROUBLE: BURNER STARTS BUT DOES NOT ESTABLISH FLAME

SOURCE	PROCEDURE	CAUSES	REMEDY
<i>Oil Supply</i>	Check tank for oil	Empty tank.	Fill tank.
	Check for water in oil tank using a dip stick coated with litmus paste	Water in oil tank	Strip tank of water
	Listen for pump whine.	Fuel supply valve closed	Open valve
		Oil filter plugged	Replace filter cartridge
		Plugged pump strainer	Clean strainer
Restriction in oil line	Repair oil line		
Open pump bleed port and start burner. Milky oil or no oil indicates loss of prime	Air leak in fuel system	Repair leak. The use of flare fittings is strongly recommended. Do not use Teflon tape on oil fittings	
<i>Oil Pump</i>	Install pressure gauge in port of fuel pump. Pressure should be 140 PSI	Pump discharge pressure set too low	Set pressure at 140 PSI
		Coupling worn or broken	Replace coupling
		Pump worn - low pressure motor overloads	Replace pump
<i>Combustion Air Requirements</i>	Check air shutter and air band	Improper air adjustment	Adjust air as indicated in manual. Set CO <sub>2</sub> to 10% min - 12% max with zero smoke
<i>Ignition Electrodes</i>	Remove and inspect nozzle line assembly	Incorrect electrode settings	Dress up tips and reset electrodes
		eroded electrode tips	
		Carboned and shorted electrodes	Clean electrodes
		Cracked porcelain insulators	Replace electrodes
<i>Nozzle</i>	Inspect nozzle for plugged orifice and distributor slots	Plugged orifice or distributor or strainer	Replace nozzle with nozzle specified in this manual and on the boiler lower jacket panel
	Inspect nozzle for correct size and specifications	Incorrect nozzle installed	
<i>Ignitor</i>	Connect ignitor leads to line voltage. Listen for spark. Check that ignitor terminals are not arcing with buss bars.	No spark or weak spark	Replace ignitor

## TROUBLE: BURNER FIRES, BUT THEN FAILS ON SAFETY

SOURCE	PROCEDURE	CAUSES	REMEDY
<i>Cad Cell</i>	Check cad cell with ohmmeter. If more than 1500 ohms, cad cell is defective or dirty	Faulty or dirty cad cell	Clean or replace cad cell
<i>Primary Control</i>	See Control Manual	Faulty primary control	Replace primary control
<i>Poor Fire</i>	Inspect flame for stability	Wrong nozzle	Replace nozzle with type specified
		Improper draft	Adjust draft to -.01-.02 W.C. overfire
		Improper air adjustment	Adjust air for a CO <sub>2</sub> of 10% min. to 12% max. and zero smoke
		Air in oil supply	Repair leaky fittings
<i>Oil Supply</i>	If burner loses flame prior to the primary control locking out, fault is in the fuel system	Air leak to fuel system Restriction in oil line Plugged fuel filter Plugged pump strainer Cold oil	Repair leak. The use of flare fittings is recommended. Clear oil line restriction. Replace filter cartridge. Clean strainer use #1 heating oil or additive to thin oil
<i>Pump</i>	Install pressure gauge in gauge port of oil pump Pressure should be 140 PSI	Pump discharge pressure incorrectly set	Set pressure at 140 PSI
		Coupling worn or broken	Replace coupling
		Pump worn	Replace pump
<i>Burner Motor</i>	Burner motor overloads. Turn off power and rotate blower by hand to check for excessive drag	Pump or blower overloading motor	Replace blower or pump
		Faulty motor	Replace motor

## TROUBLE: HIGH NET STACK TEMPERATURES

SOURCE	PROCEDURE	CAUSES	REMEDY
<i>Nozzle</i>	Inspect nozzle for correct size and type Check pump pressure with pump gauge	Incorrect nozzle	Replace nozzle with nozzle specified
		Nozzle overfiring due to high pump pressure	Reduce pump pressure to 140 PSI
<i>Heat Exchanger</i>	Check heat exchanger surfaces for soot or scale fouling	Heat exchanger fouled	Clean heat exchanger

## TROUBLE: BURNER FIRES BUT PULSATES

SOURCE	PROCEDURE	CAUSES	REMEDY
<i>Draft</i>	Take a draft reading. Draft should be $-.01''$ $-.02''$ W.C. overfire	Insufficient draft	Increase draft setting. Be sure chimney is clean and meets the minimum size requirements.
		Excessive draft	Reduce draft settings. Install second draft regulator if necessary
<i>Draft Regulator</i>	Inspect draft regulator for correct location	Improper installation	Move draft regulator to correct location
<i>Combustion Air</i>	Inspect installation for adequate incoming make-up air	Insufficient amount of make-up air in boiler room	Provide openings that freely communicate with outside.
	Adjust combustion air and take a CO <sub>2</sub> reading	Improper air intake adjustment	Adjust CO <sub>2</sub> level to 10% min. 12% max. and zero smoke
<i>Oil Supply</i>	Bleed pump and inspect for air	Air leak in fuel system	Repair air leak Use flare fittings only
<i>Pump Pressure</i>	Install pressure gauge in port of oil pump. Pressure should be 140 PSI	Pump discharge pressure incorrectly set	Set pressure at 140 PSI
		Coupling worn or broken	Replace coupling
<i>Nozzle</i>	Inspect nozzle for plugged orifice and distributor slots	Plugged orifice or distributor Plugged nozzle strainer	Replace nozzle with correct nozzle as specified

## TROUBLE: TOO MUCH HEAT

SOURCE	PROCEDURE	CAUSES	REMEDY
<i>Circulator</i>	Check to see if operating control is working properly	Circulator does not stop running	Repair operating control
<i>Thermostat</i>	Check thermostat settings and calibration	Thermostat set too high	Reset thermostat
		Thermostat defective	Replace thermostat.
		Thermostat out of calibration	Recalibrate.
<i>Flow or Zone Valve</i>	Check to see if flow valve/zone valve is operating properly	Flow valve/zone valve dirty and stuck	Replace zone valve Replace flow valve

## TROUBLE: INSUFFICIENT HEAT

SOURCE	PROCEDURE	CAUSES	REMEDY
<i>Circulator</i>	Check if circulator is operational.	Pump binding	Replace pump
		Circulator motor burned out	Replace circulator motor
		Wiring from operating control defective	Repair wiring
		Operating control defective	Repair or replace operating control
<i>Thermostat</i>	Check thermostat settings	Settings too low	Increase setting
	Check thermostat location	Bad location due to heat build up	Move thermostat to a better location
	Check thermostat calibration	Out of calibration	Recalibrate
<i>Flow Valve/ Zone Valve</i>	Check flow valve/zone valve for sticking in partially closed position	Flow valve/zone valve not opening fully	Clean or replace flow valve/zone valve
<i>Radiation</i>	Check for air in radiators	Radiators airbound	Bleed radiators
	Check to see if radiators are sized properly	Radiators inadequate	Install adequate radiation
<i>Tankless Coil</i>	Check usage of domestic hot water	Demand too large	Install flow regulator Additional boiler capacity required
<i>Heat Exchanger</i>	Check heat exchanger for soot or scale accumulation	Insufficient heat transfer	Clean heat exchanger
<i>Burner</i>	Check pump pressure with pressure gauge	Insufficient pump pressure	Increase pressure to 140 PSI
<i>Nozzle</i>	Check nozzle for size and spray angle	Wrong nozzle installed	Install specified nozzle
	Check nozzle for plugged orifice, scoured surface	Nozzle underfiring due to defective nozzle	Replace nozzle

## TROUBLE: INSUFFICIENT DOMESTIC HOT WATER

SOURCE	PROCEDURE	CAUSES	REMEDY
<i>Tankless Coil</i>	Analyze capacity vs. usage	Insufficient coil capacity	Install larger coil
	Check coil for fouling	Hard water scaling	Install soft water system Clean coil
<i>Operating Control</i>	Check operating control setting	Setting too low	Set operating control low limit to 160°F
<i>Heat Exchanger</i>	Inspect coils for fouled surfaces and/or flow restrictions	Flow restriction Fouled surfaces or heat exchanger	Remove restriction Clean heat exchanger surfaces

# ELECTRICAL DIAGRAM FOR EM SERIES BOILERS TO CONNECT BURNER TO AQUASTAT

(APPLIES TO CARLIN CHIMNEY VENT AND RIELLO CHIMNEY VENT BURNERS)

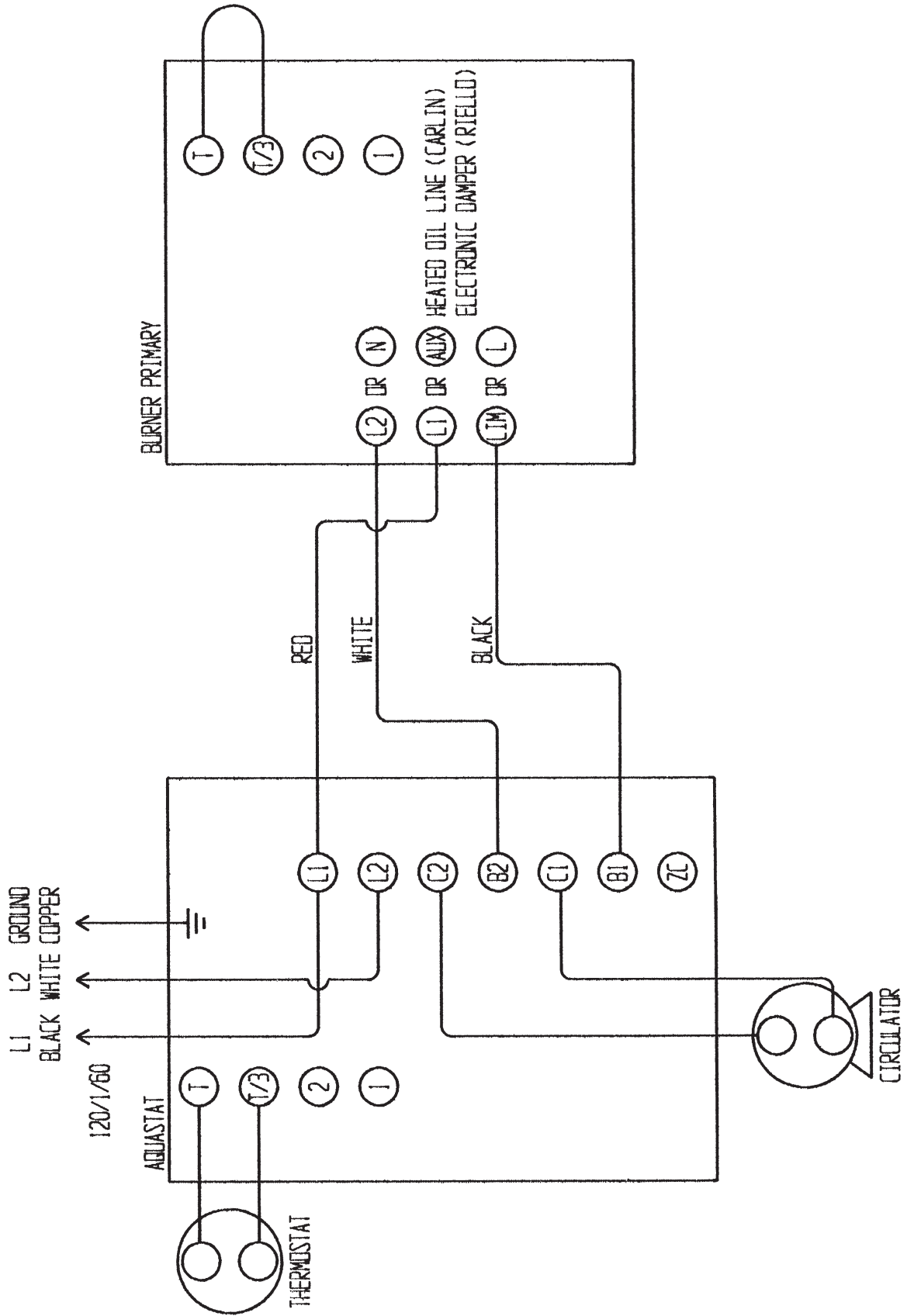

# ELECTRICAL DIAGRAM FOR EM SERIES BOILERS TO CONNECT BURNER TO AQUASTAT

(APPLIES TO BECKETT CHIMNEY VENT BURNERS)

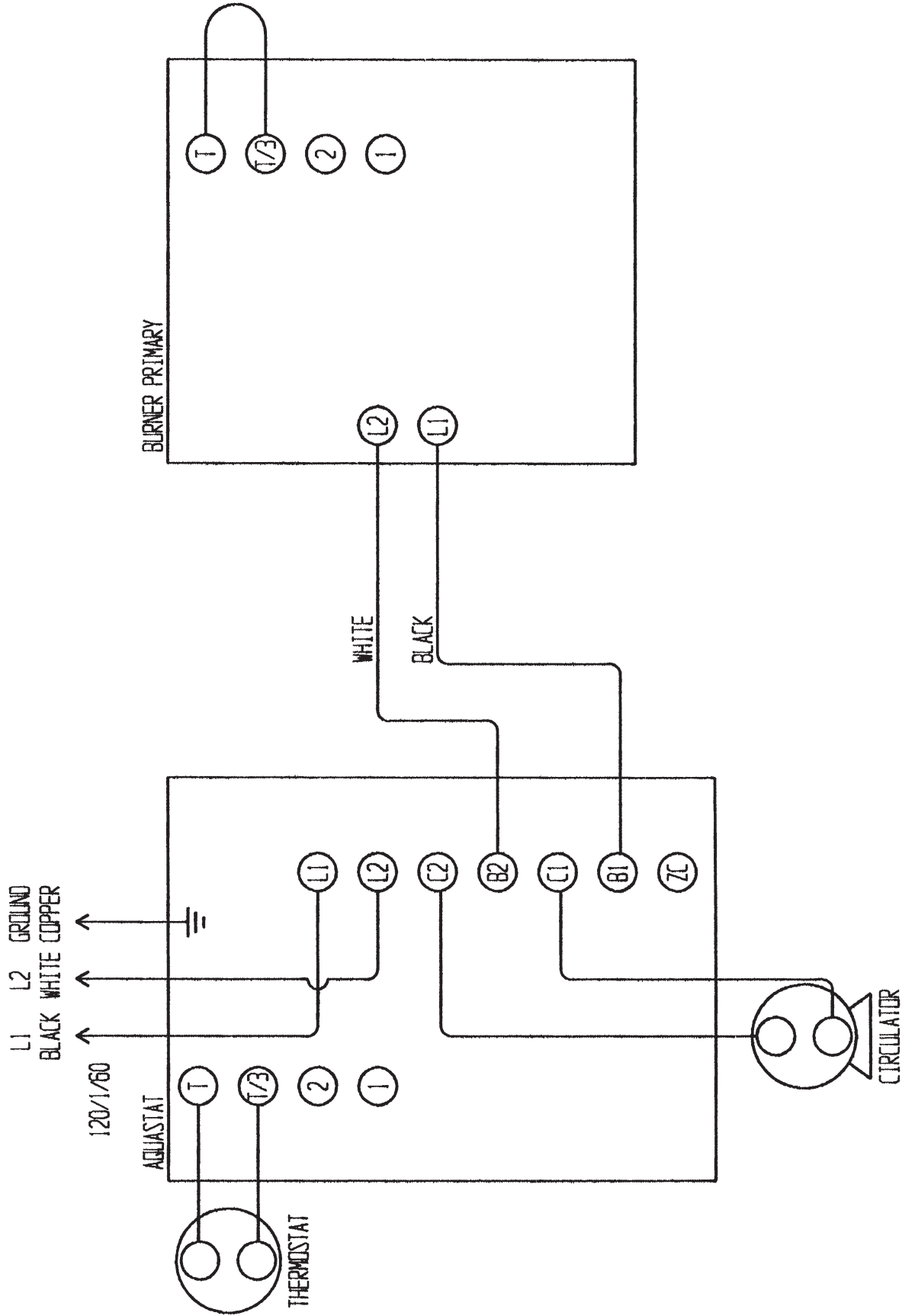

## BURNER SERVICE SET-UP RECORDS

	1	2	3	4	5
1. Date					
2. Model Number					
3. Firing Rate					
4. Pump Pressure*					
5. CO2					
6. "0" Smoke					
7. Gross Stack°F					
8. Draft Over Fire					
9. Replaced Filter Yes/No					
10. Replaced Nozzle Yes/No					
11. Clean Pump Filter Yes/No					
12. Inspect Coil Gasket					
13. Check for Leaks @ plugs/fittings					
14. Brush Clean Flue Tube Passages					
15. Vacuum Chamber/Flue Tubes					
16. Clean Blower Wheel					
17. Check/Set Electrodes					

## BURNER SERVICE SET-UP RECORDS

	6	7	8	9	10
1. Date					
2. Model Number					
3. Firing Rate					
4. Pump Pressure*					
5. CO2					
6. "0" Smoke					
7. Gross Stack°F					
8. Draft Over Fire					
9. Replaced Filter Yes/No					
10. Replaced Nozzle Yes/No					
11. Clean Pump Filter Yes/No					
12. Inspect Coil Gasket					
13. Check for Leaks @ plugs/fittings					
14. Brush Clean Flue Tube Passages					
15. Vacuum Chamber/Flue Tubes					
16. Clean Blower Wheel					
17. Check/Set Electrodes					

# Columbia Emerald Boiler/Burner Unit Specifications

## BOILER/BURNER UNIT SPECIFICATIONS - BECKETT AFG

Boiler Model	Pump Pressure PSI	Burner Hd.	Delavan Nozzle	Approximate Air Setting Shutter	Air Setting Band
EM - 85	140	F-3	.65 80°B	8	0
EM-100	140	F-3	.75 80°B	10	0
EM-3100	140	F-3	.85 80°B	10	0
EM-110	140	F-6	.85 80°B	10	0
EM-3125	140	F-6	1.00 80°B	10	2
EM-125	140	F-6	1.00 80°B	10	2
EM-135	140	F-6	1.10 80°A	10	2
EM-150	140	F-12	1.25 80°A	9	0
EM-165	140	F-12	1.35 80°A	10	0
EM-175	140	F-12	1.50 80°A	10	1
EM-200	140	F-22	1.65 80°A	10	2

## BOILER/BURNER UNIT SPECIFICATIONS - RIELLO 5F BURNER

Boiler Model	Pump Pressure PSI	Delavan Nozzle	Approximate Air Setting Band
EM - 85	150	.65 60°A	1.75
EM-100	150	.75 60°A	1.75
EM-110	150	.85 60°A	2.25
EM-125	150	1.00 60°A	2.75
EM-135	150	1.10 80°A	3.25
EM-150	150	1.25 80°A	3.8
EM-165	150	1.35 80°A	2.0
EM-175	150	1.50 80°A	2.8
EM-200	150	1.65 80°B	2.75

## BOILER/BURNER UNIT SPECIFICATIONS - CARLIN EZ-1 BURNER

Boiler Model	Pump Pressure PSI	Delavan Nozzle	Approximate Air Setting Band
EM - 85	140	.65 70°A	.65
EM-100	140	.75 70°A	.65
EM-110	140	.85 70°A	.75
EM-125	140	1.00 60°B	.85
EM-135	140	1.10 60°B	.90
EM-150	140	1.25 60°B	1.25
EM-165	140	1.35 60°B	1.35
EM-175	140	1.50 70°A	2.00
EM-200	140	1.65 70°A	2.00

Notice: All settings are approximate. Check the Installer Serviceman Label on the boiler for updates and use instruments to make final settings in accordance with the procedure in this manual.

